

Shower stretcher 1500/1700/1900

Linido

Manual - English

Manual - Svenska

Manual - Norsk

Manual - Dansk

Käyttöohje - Suomi

Gebrauchsanweisung - Deutsch

Handleiding - Nederlands

Manual - Français

Manual - Italiano

Manual - Español



LI2403



LI2404



LI2407



LI2408

Art.no.:

LI2403.150x-xx

LI2403.170x-xx

LI2403.190x-xx

LI2404.150x-xx

LI2404.170x-xx

LI2404.190x-xx

LI2407.150x-xx

LI2407.170x-xx

LI2407.190x-xx

LI2408.150x-xx

LI2408.170x-xx

LI2408.190x-xx



Max: 150 kg/330 lbs

**Direct Healthcare
Group**

Advancing Movement & Health®

**EN Visual inspection**

Inspect the product regularly. Check to ensure that material is free from damage.

SE Visuell inspektion

Gör regelbundna funktionskontroller av produkten. Kontrollera att materialet är helt fritt från skador.

NO Visuell inspeksjon

Gjør regelmessige funksjonskontroller av produktet. Kontroller at materialet er helt og uten skader.

DK Visual inspektion

Foretag regelmæssige funktionskontroller af sengebordet. Kontroller, at materiale er helt og ikke udviser tegn på beskadigelse.

FI Silmämääräinen tarkastus

Tarkasta tuotteen toimivuus säännöllisesti. Tarkasta, ettei materiaalissa ole mitään vaurioita.

DE Sichtprüfung

Unterziehen Sie das Hilfsmittel regelmäßigen Funktionskontrollen. Vergewissern Sie sich, daß das Material unbeschädigt ist.

NL Visuele controle

Inspecteer het product regelmatig. Controleer op mogelijke beschadigingen van het materiaal.

FR Inspection visuelle

Effectuer des inspections régulières du fonctionnement du produit. Vérifier que le matériau est entièrement exempt de dommages.

IT Ispezione visiva

Testare il funzionamento del prodotto regolarmente. Verificare che il materiale non sia danneggiato.

ES Inspección visual

Realice periódicamente un control de funcionamiento del producto. Asegúrese de que el material no presente ningún tipo de desperfecto.

EN Before use

Ensure that the product is correctly mounted/installed.

SE Före användning

Kontrollera att produkten är rätt monterad/installerad.

NO Før bruk

Kontroller at produktet er korrekt installert.

DK Før brug

Kontroller, at produktet er korrekt installeret.

FI Ennen käyttöä

Tarkasta, että tuote on asennettu oikein.

DE Vor der Benutzung

Prüfen Sie das Produkt auf korrekte Montage.

NL Voor gebruik

Zorg ervoor dat het product juist is gemonteerd.

FR Avant l'utilisation

Vérifier que le produit est correctement installé.

IT Prima dell'uso

Verificare che il prodotto sia installato correttamente.

ES Antes de su uso

Compruebe que el producto esté correctamente instalado.

**EN Always read the manual**

Keep the manual where it is easily accessible for users of the product.

SE Läs alltid manualen

Förvara manualen tillgänglig för användare av produkten.

NO Les alltid manualen

Oppbevar manualen tilgjengelig for brukere av produktet.

DK Læs altid manualen

Opbevar manualen tilgængelig for brugere af produktet.

FI Lue aina käyttöohje

Säilytä käyttöohje tuotteen käyttäjien saatavilla.

DE Lesen Sie stets die Gebrauchsanweisung

Verwahren Sie die Anleitung so, dass sie der Anwender des Produktes rasch zur Hand hat.

NL Lees altijd de handleiding

Bewaar de handleiding zo dat deze voor gebruikers van het product altijd beschikbaar is.

FR Toujours lire le manuel

Conserver le manuel pour qu'il soit accessible aux utilisateurs du produit.

IT Leggere sempre il manuale

Tenere il manuale delle istruzioni in un luogo facilmente accessibile agli operatori che utilizzano il prodotto.

ES Lea siempre el manual

Guarde el manual en un lugar accesible para el usuario del producto.

Using/Användning/Bruk/Brug/Käyttö/Anwendung/Gebruik/Utilisation/Utilizzo/Empleo

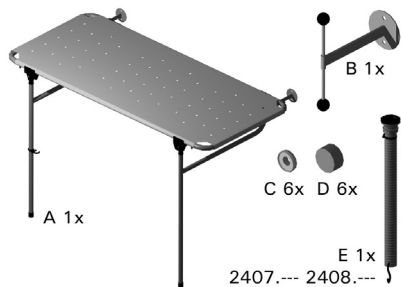

GB: Lock before use. Do not cut leg supports!

SE: Lås före användning. Kapa ej stödbenen!

NO: Leses før bruk. Kapp ikke støttebeina!

DK: Lås før brug. Skær ikke i benstøtterne!

FI: Lukitse ennen käyttöä. Jalkatukia ei saa lyhentää!

DE: Vor Benutzung schließen. Die Bodenstützen dürfen nicht selbstständig gekürzt werden!

NL: Vergrendelen voor gebruik. Steunpoten niet inkorten!

FR: Véroùiller avant usage. Ne jamais recouper les pieds de support!

IT: Fissare prima dell'uso. Non tagliare le gambe ribaltabili!

ES: Fijar antes de usar. No cortar las patas!

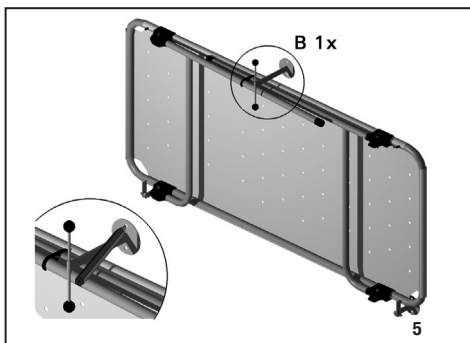
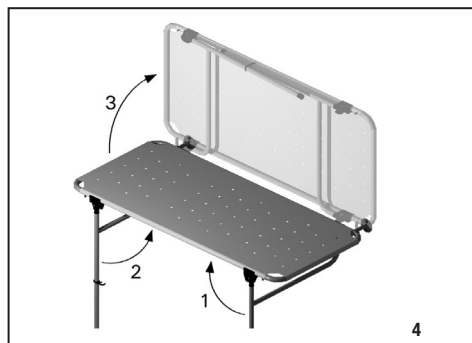
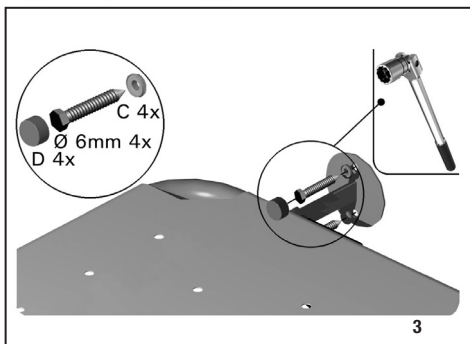
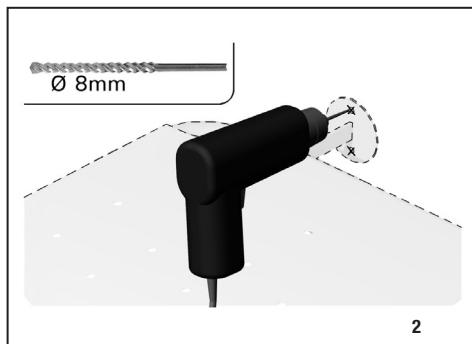
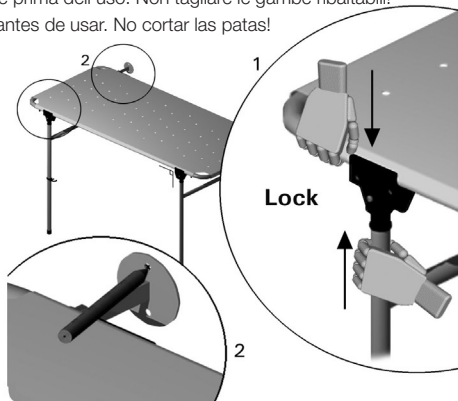
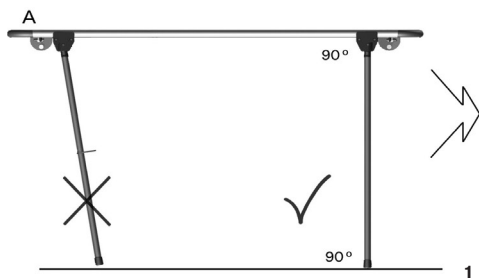

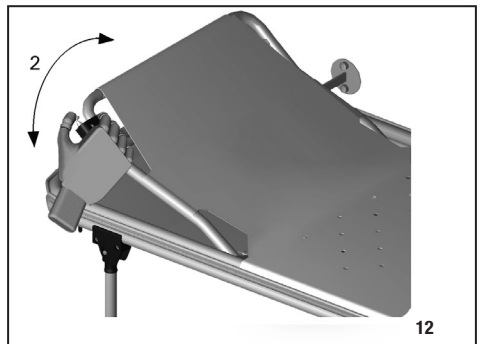
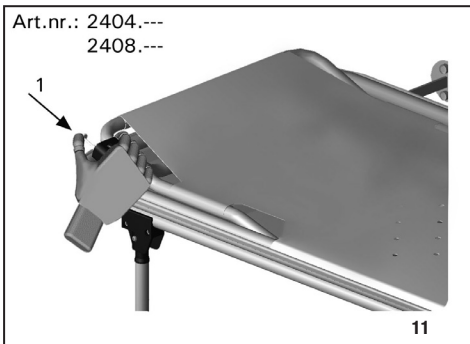
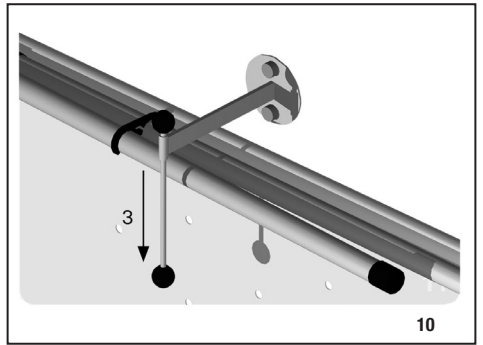
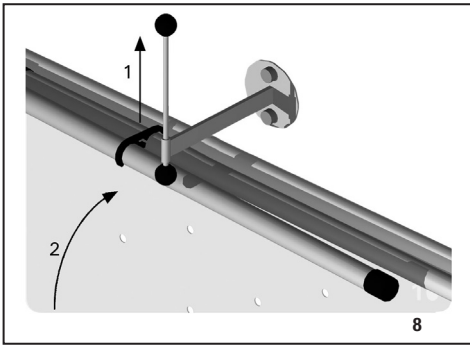
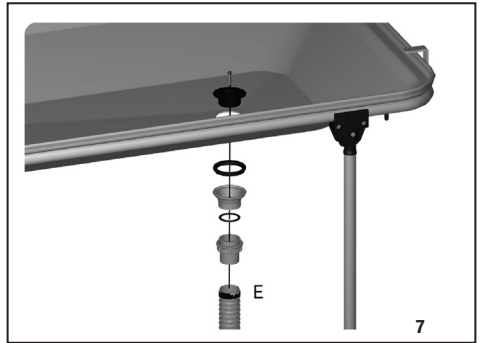
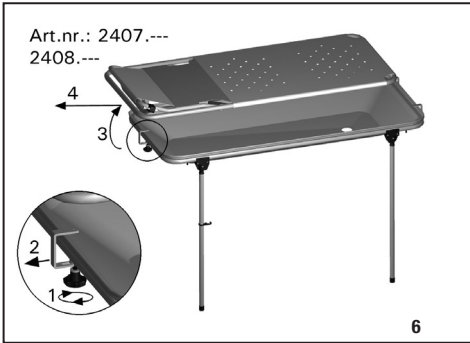
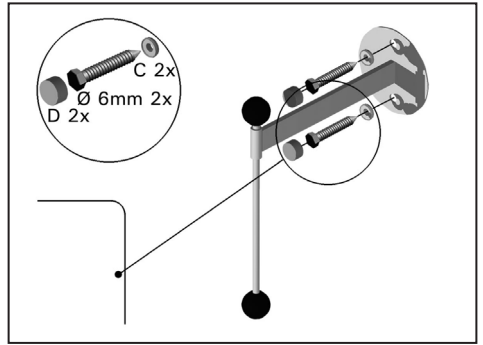
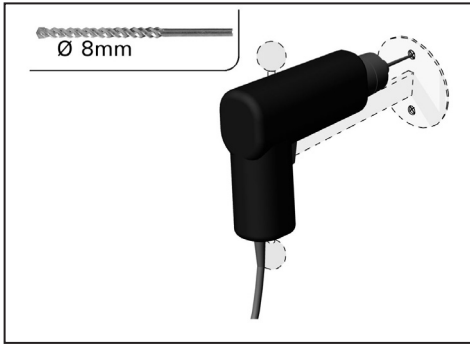

Maintenance/Rengöring/Vedlikeholdsråd/Vedligeholdelse/Hoito-ohje/Pflegeanleitung/ Onderhoud/Conseils d'entretien/Cura del prodotto/Cuidado del producto

EN Clean regularly with normal household detergent. Do not use aggressive cleaners. Direct Healthcare Group is not liable for damage caused by improper mounting/use.

SE För rengöring använd normalt och inte aggressivt rengöringsmedel. Direct Healthcare Group står ej ansvarig för skador som uppstår pga. felaktig montering/användning.

NO For rengjøring bruk nøytralt/normalt rengjøringsmiddel og ikke etsende midler. Direct Healthcare Group står ikke ansvarlig for skader som kan oppstå pga feilaktig motering/bruk.

DK Efter brug tjernes sæberester. Der må ikke anvendes hårde rengøringsmidler. Direct Healthcare Group er ikke ansvarig for skader opstået pga. torkert montering/brug.

FI Puhdistusta säännöllisesti käyttäen kodin yleispuuaineita. Älä käytä voimakkaita liuottimia. Direct Healthcare Group ei ole vastuussa vahingosta, joka johtuu virheellisestä asennuksesta tai käytöstä.

DE Beseitige nach Benutzung Seifenreste. Kein aggressives Reinigungsmittel verwenden. Direct Healthcare Group ist nicht haftbar für Schäden die durch unsachgemäße Befestigung/Benutzung oder falsches Befestigungsmaterial entstanden sind.

NL Verwijder na gebruik zeepresten. Gebruik geen agressieve schoonmaakmiddelen. Direct Healthcare Group is niet aansprakelijk voor schade als gevolg van onjuiste bevestiging/gebruik.

FR Laver régulièrement avec un détergent ménager. Ne pas utiliser de détergent agressif. Direct Healthcare Group n'est pas responsable des dommages causés par un montage/utilization incorrect.

IT Pulire periodicamente, utilizzando detergenti di uso corrente per la casa. Non usar prodotti abrasivi e corrosivo. Direct Healthcare Group non è responsabile per i danni causati dal montaggio/uso improprio.

ES Limpiar regularmente con cualquier detergente no corrosivo. No usar lejía ya que es muy corrosivo. Direct Healthcare Group no se hace responsable de cualquier deterioro causado por un montaje/uso incorrecto.

Accessories/Tillbehör/Tilbehør/Lisävarusteet/Zubehör/Accessoires/Accessori/Accesorios

Art. no:	Product name:	Description:
LI2807.0000-00	Wall mounting set	For wall mounting of all LinidoSolutions™ shower stretchers.
LI2860.0000-00	Insulation set M6 x 4	For electrical insulation and covering of fixing points, spare part for all shower stretchers.
LI2490.125-xx	Removable side fence	1250 x 170 mm, including plastic mounting clamps, for all LinidoSolutions™ shower stretchers.
LI2590.125x-xx	Hinged side fence	1250 x 235 mm, including plastic mounting clamps, for all LinidoSolutions™ shower stretchers.

Dimensions/Måttbeskrivning/Målbekrivelse/Mitat/Maßbeschreibung/Afmetingen/ Dimensioni/Dimensiones

Shower stretcher, flat

Art. no. LI2403.150x-xx -- LI2403.190x-xx

mm/inch

A	120/4,7
B	900/35,4
C	2xØ8,5/2xØ0,3
D	
E	1065/41,9
F	120/4,7
G	2xØ8,5/2xØ0,3
H	
I	685/26,9
J	180/7
K	2xØ8,5/2xØ0,3
L	670/26,3
M	80/3,1
N	755/29,7
O	785/30,9
P	52/2
Q	52/2

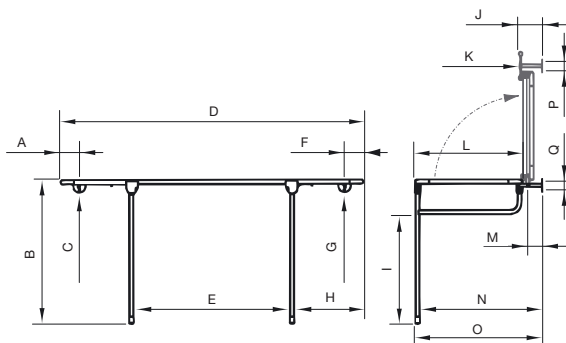

Art. No	D	H
LI2403.150	1490/58,6	185/7,2
LI2403.170	1690/66,5	285/11,2
LI2403.190	1890/74,4	385/15,1

Shower stretcher, adjustable backrest

Art. no. LI2404.150x-xx -- LI2404.190x-xx

mm/inch

A	900/35,4
B	
C	5-80°
D	2xØ8,5/2xØ0,3
E	
F	1065/41,9
G	120/4,7
H	2xØ8,5/2xØ0,3
I	
J	180/7
K	2xØ8,5/2xØ0,3
L	670/26,3
M	560/22
N	110/4,3
O	790/31,1
P	815/32
Q	52/2
R	52/2

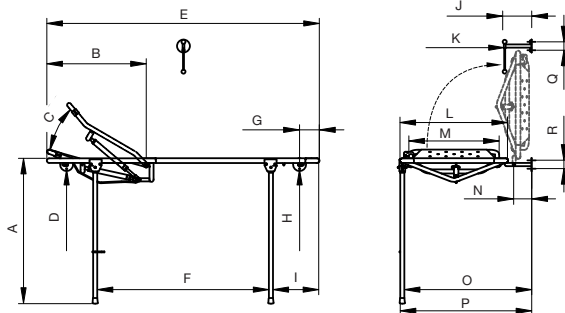

Art. No	B	E	I
LI2404.150	465/18,3	1490/58,6	185/7,2
LI2404.170	615/24,2	1690/66,5	285/11,2
LI2404.190	615/24,2	1890/74,4	385/15,1

Shower stretcher, flat, with water reciever and flexible drain hose Art. no. LI2407.150x-xx -- LI2407.190x-xx

mm/inch

A	
B	2xØ8,5/2xØ0,3
C	
D	1065/41,9
E	2xØ8,5/2xØ0,3
F	180/7
G	2xØ8,5/2xØ0,3
H	52/2
I	690/27,1
J	670/26,3
K	155/6,1
L	845/33,2
M	870/34,2
N	52/2

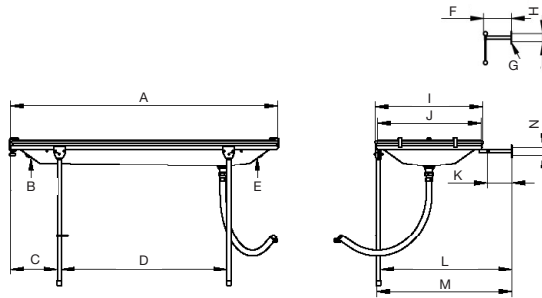

Art. Nr	A	C
LI2407.150	1520/59,8	200/7,8
LI2407.170	1720/67,7	300/11,8
LI2407.190	1920/75,5	400/15,7

Shower stretcher, adjustable backrest, with water reciever and flexible drain hose

Art. no. LI2408.150x-xx -- LI2408.190x-xx

mm/inch

A	
B	
C	5-80°
D	2xØ8,5/2xØ0,3
E	925/36,4
G	1065/41,9
H	2xØ8,5/2xØ0,3
I	180/7
J	2xØ8,5/2xØ0,3
K	52/2
L	690/27,1
M	560/22
N	155/6,1
O	845/33,2
P	870/34,2
Q	52/2

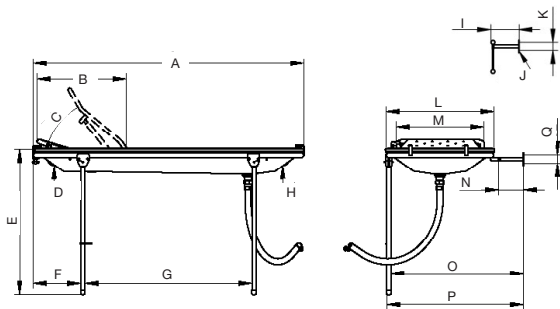

Art. Nr	A	B	F
LI2408.150	1520/59,8	465/18,3	200/7,8
LI2408.170	1720/67,7	615/24,2	300/11,8
LI2408.190	1920/75,5	615/24,2	400/15,7

Linido

Direct Healthcare Group's Linido product line is a wide range of high quality safety products designed to provide ergonomic support, comfort and increased independence for the user in various bathing, showering and toileting situations.

Contact your local distributor if you have any questions about the product and its use.

See www.directhealthcaregroup.com for a complete list of distributors.

Always make sure that you have the right version of the manual.

The most recent editions of manuals are available for downloading from our website, www.directhealthcaregroup.com

Direct Healthcare Group

Advancing Movement & Health®

Direct Healthcare Group
Weteringweg 9, 2641 KM Pijnacker

Tel: +31 (0)15 369 54 40
Fax: +31 (0)15 369 71 64

www.directhealthcaregroup.com
info.nl@directhealthcaregroup.com